

# Talia Suspended

Suspended glass sphere

Innovation.  
Collaboration.  
Illumination.



Indoor Lighting

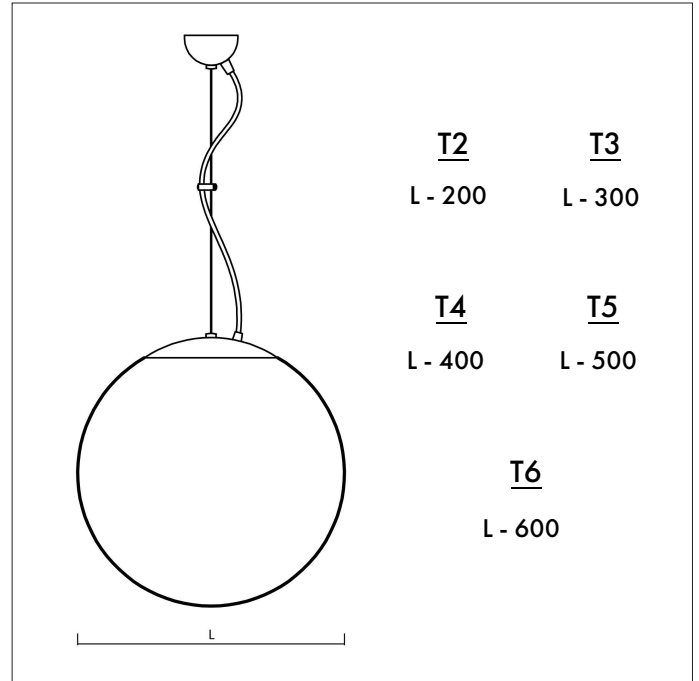

## Key features

- IP40 suitable for internal environments
- Impact rating of IK01
- Efficacy of up to 138lm/W
- Nominal life-time of 50,000 h (L80/B10)
- Colour stability with 3 step MacAdam

## Options

- For DALI dimmable suffix: /DIM
- For Casambi enabled suffix: /CAS
- For wireless dimmable system suffix: /WD

i.e.: Talia 20W, 2760lm, 4000K, = **TAL/2760/4**

CRI 80 as standard, CRI 90 available on request.

Part No.	Lm	W	Lm/W	Weight	CCT
TAL/2/1000/4	1000	9	111	1.6kg	4000K
TAL/3/2760/4	2760	20	138	3kg	4000K
TAL/4/3620/4	3620	27	134	5.8kg	4000K
TAL/5/5450/4	5450	41	138	6.9kg	4000K
TAL/6/6290/4	6290	48	131	8.1kg	4000K

For more information, please contact [Sales@ldl.lighting](mailto:Sales@ldl.lighting)