

# TR2 Surface

## Emergency Spotlight

Innovation.  
Collaboration.  
Illumination.



Emergency Lighting

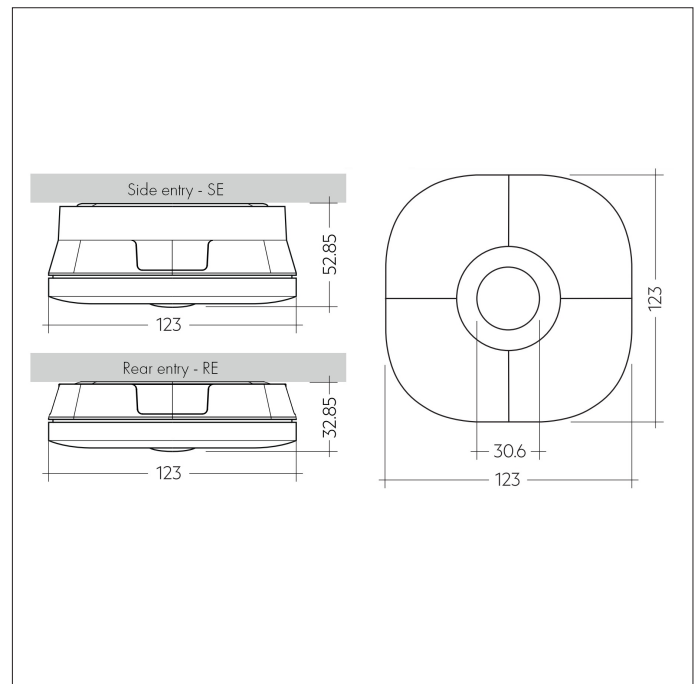

### Key features

- Supplied with 3 lenses, Open Area, Corridor and Spot
- White and Black finishes available
- Compact Design
- Rear or Side Entry
- Lithium Iron Phosphate battery
- IP20 suitable for internal environments
- Impact rating of IK07
- High colour rendering index CRI > 80
- Colour stability with 3 step MacAdam

### Options

- For side cable entry suffix: /SE
- For rear cable entry suffix: /RE
- For black finish suffix: /BLK
- For white finish suffix: /WHI
- For Corridor optic: /COR
- For Spot optic: /SP
- For Open Area optic: /OA

i.e.: TR2 surface, 3W, high output 400lm,  
Corridor optic, non-maintained, rear entry, white  
finish = **TR2/SF/3/HO/COR/NM/RE/WHI**

Part No.	Lm	W	Lm/W	Weight	CCT
TR2/SF/2	217	2	109	0.3kg	6500K
TR2/SF/3/HO	400	3	133	0.3kg	6500K

For more information, please contact [Sales@ldl.lighting](mailto:Sales@ldl.lighting)

