

# Cameron

## Surface Mounted Bulkhead

Innovation.  
Collaboration.  
Illumination.



Indoor Lighting

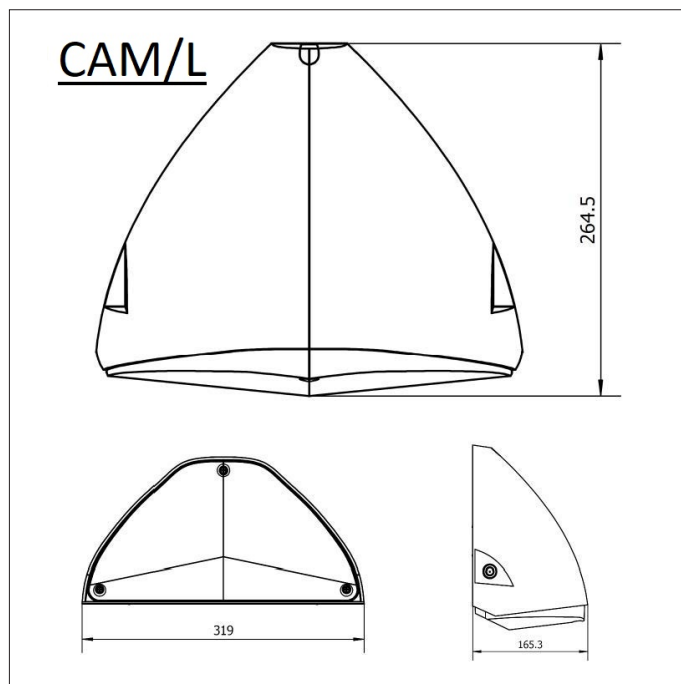

### Key features

- IP65 suitable for external/wet environments
- Impact rating of IK10
- Efficacy of up to 136lm/W
- Nominal life-time of 60,000 h (L80/B10)
- High colour rendering index CRI > 80

### Options

- For 3hr self-contained emergency suffix: /EMR
- For DALI addressable emergency suffix: /EMP

i.e.: Cameron Large, 21W, 2541lm, 4000K = CAM/L/2541/4

Part No.	Lm	W	Lm/W	CCT	Weight
CAM/S/548/3	548	4	137	3000K	0.32kg
CAM/S/584/4	584	4	146	4000K	0.32kg
CAM/M/1384/3	1384	10	138	3000K	1.2kg
CAM/M/1432/4	1432	10	143	4000K	1.2kg
CAM/L/2461/3	2461	21	117	3000K	2.3kg
CAM/L/2541/4	2541	21	121	4000K	2.3kg

For more information, please contact [Sales@ldl.lighting](mailto:Sales@ldl.lighting)

