

Elijah

Track Spotlight

Innovation.
Collaboration.
Illumination.



Indoor Lighting

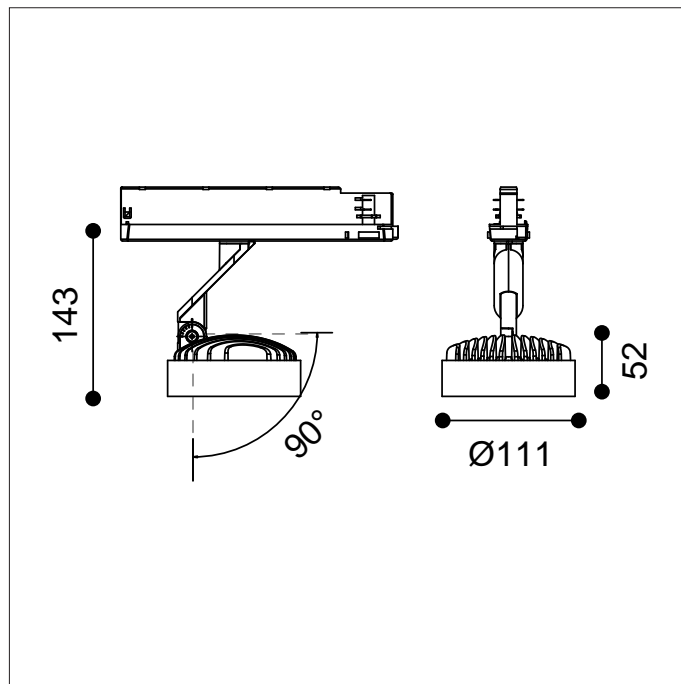

Key features

- IP20 suitable for internal environments
- Impact rating of IK06
- Efficacy of up to 123lm/W
- Nominal life-time of 90,000 h (L80/B10)
- Colour stability with 3 step MacAdam
- Very high colour rendering index CRI > 90

Options

- For 15° reflector suffix: /15D
- For 20° reflector suffix: /20D
- For 35° reflector suffix: /35D
- For black finish suffix: /BLK
- For white finish suffix: /WHI
- For DALI dimmable suffix: /DIM
- For Casambi enabled suffix: /CAS

i.e.: Elijah Trackspotlight, 18W, 2208lm, 3000K, 20° reflector, black finish, Casambi enabled = **ELI/3000/3/20D/BLK/CAS**

Accessories



Honeycomb louver



Striped glass



Snoot

Part No.	Lm	W	Lm/W	Weight	CCT
ELI/1500/3	1500	12	123	1.3kg	3000K
ELI/2210/3	2208	18	120	1.3kg	3000K
ELI/2870/3	2873	25	116	1.3kg	3000K

